

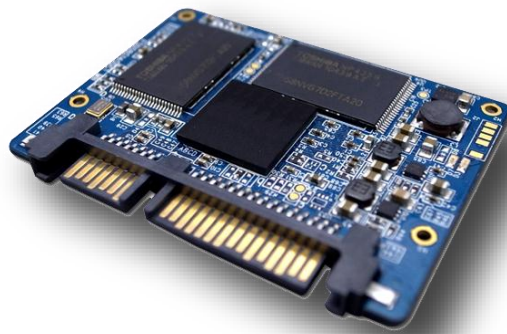

Industrial SSD SlimSATA (MO-297) Specification

Ver. 1.2





REVISION HISTORY

Revision	History	Draft Date
1.0	Preliminary Release	6/27/2011
1.1	Part# Revised	7/7/2011
1.2	Added "I" Temp MLC Support	8/19/2011

Table of Contents

1. General Description	4
1.1 Overview	4
1.2 Block Diagram	4
2. Product Specifications	6
2.1 Support Capacity.....	6
2.2 Performance	6
2.3 ECC scheme.....	6
2.4 Environmental Conditions.....	6
3. Electrical Specifications	7
3.1 Pin and Signal assignment	7
3.2 Supply voltage.....	8
3.3 Power Consumption	8
4. Command Description.....	9
4.1 ATA Command List.....	9
4.2 Identify Device Data.....	10
5. Physical Dimension	13
6. Part Numbers.....	14

1. General Description

1.1 Overview

Unity Digital SlimSATA SSD delivers all the advantages of Flash Disk technology with the Serial ATA II interface, fully compliant with standard half-slim SSD form factor (JEDEC MO-297). SATA Drives are replacing the older and slower (PATA) interface in embedded environments. The Unity Digital SlimSATA SSD is based on a standard 7-pin interface for data segment and 15-pin for power segment, designed to operate at a maximum operating frequency of 150MHz with 30MHz external crystal. Its capacity could provide a wide range from 4GB to up to 128GB (MLC). Also it can reach maximum 200 MB/s read as well as 180 MB/s write high performance based on MLC flash (with 64MB DDR enabled and measured by CrystalDiskMark v3.0). The power consumption of Flash Disk is much lower than traditional Hard Drive.

1.2 Block Diagram

Flash Controller Block Diagram

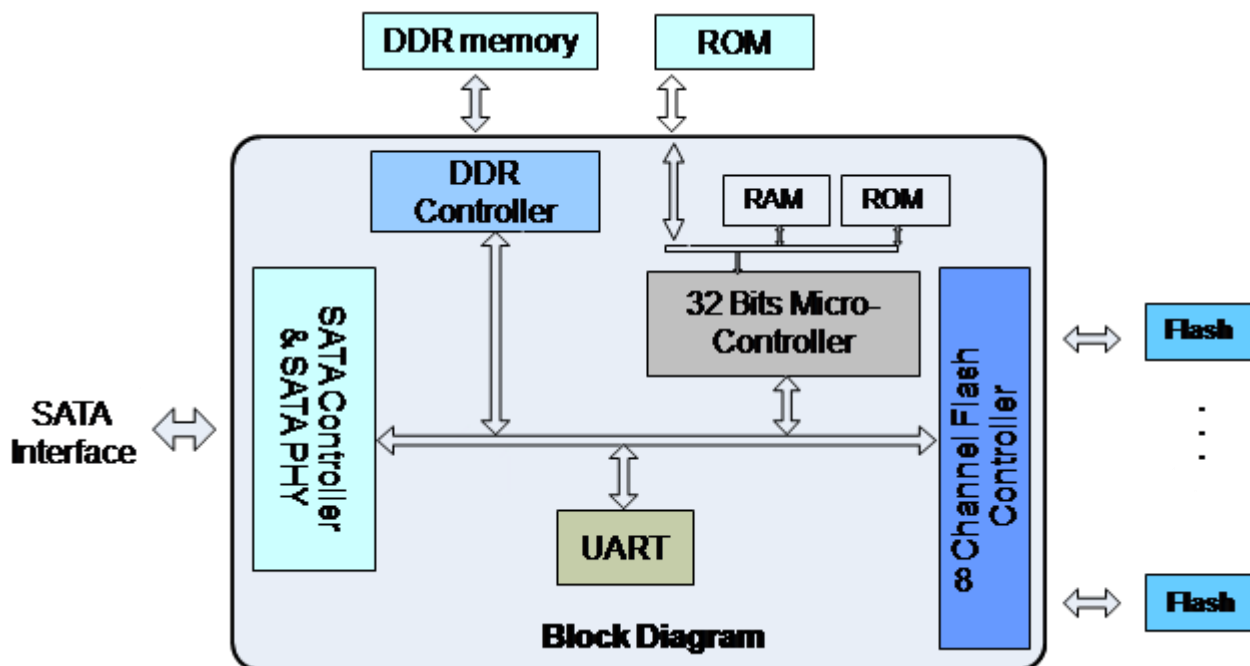

Electrical/Physical interface

- a. SATA interface
 - Support SATA 1.5Gbps and 3.0Gbps interface.
- b. DDR1 IO
 - Support DDR1 I/O interface
- c. Flash IO
 - Support 1.8V and 3.3V voltage level
 - Support 1.8V for ONFI Flash
 - Support 3.3V for conventional Asynchronous Flash

Controller Features

- a. SATA II
 - SATA Revision 2.6 compliant.
 - Compatible with SATA 1.5Gbps and 3Gbps interface.
 - Power management supported
 - Support expanded register for SATA protocol 48 bits addressing mode
 - Embedded BIST function of SATA PHY for low cost mass production
- b. NAND Flash Interface
 - Build - in hardware ECC circuit (48bit/2KB).
 - Support all types of SLC and MLC Large Block 8KB/page NAND flash.
 - ONFI2.0 Interface support: 4 channels max
 - Bus Width: 8/16 bit.
 - Support 1pc to 4pcs TSOP/ULGA Flash chip enable.
- c. DDR1 interface
 - 16 bit data bus.
 - Data Rate: 320Mbps.
 - Support Capacity : 64MB
- d. Build in 32 bits micro - controller
- e. UART

2. Product Specifications

2.1 Support Capacity

SLC, 4G-32G

MLC, 16G-128G

2.2 Performance

- SLC

Read: 120MB/s (Max.)

Write: 100MB/s (Max.)

- MLC

Read: 200MB/s (Max.)

Write: 180MB/s (Max.)

2.3 ECC scheme

Support 48/32/28 bit ECC correct per 2K Byte data

2.4 Environmental Conditions

☆ Operation Temp. Range

- 0~+70°C (SLC & MLC)

- -40~+85°C (SLC & MLC)

☆ Storage Temp. Range

- -40~+85°C

☆ Humidity: RH = 95% under 55°C

☆ Shock 1500G/0.5ms / Vibration 80 - 2000Hz/20G

☆ Booting feature from Windows OS

☆ Acquired RoHS, WHQL, CE/FCC certificates

☆ Acoustic = 0dB

3. Electrical Specifications

3.1 Pin and Signal assignment

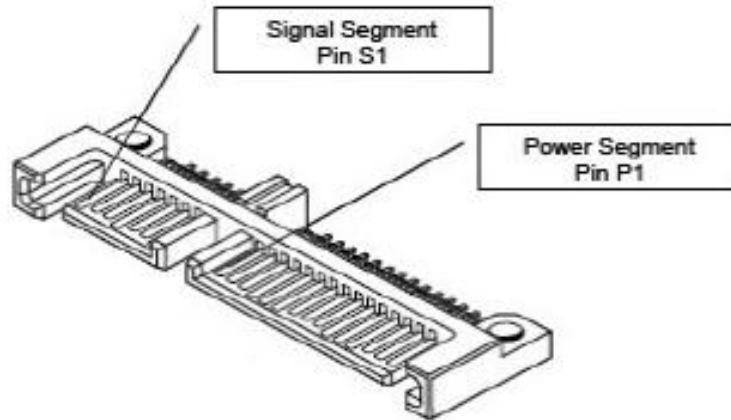

Signal Segment Pinout

Pin Number	Function	Description
S1	GND	2 nd mate
S2	A+	Differential signal pair A
S3	A-	
S4	GND	2 nd mate
S5	B-	Differential signal pair B
S6	B+	
S7	GND	2 nd mate

Power Segment Pinout

Pin Number	Function
P1	Not Used (3.3V)
P2	Not Used (3.3V)
P3	Not Used (3.3V Pre-Charge)
P4	GND
P5	GND
P6	GND
P7	5V Pre-Charge
P8	5V
P9	5V
P10	GND
P11	RESERVED
P12	GND
P13	Not Used (12V Pre-Charge)
P14	Not Used (12V)
P15	Not Used (12V)

3.2 Supply voltage

Parameter	Rating
OP. voltage	5V +/- 5%
Max. Ripple	100mV , 0~30MHz

3.3 Power Consumption

Parameter	Value (mA)
Idle	39.8
Write	496.5
Read	249.4

* This is based on 32GB (64Gbit MLC x4) statistics.

4. Command Description

4.1 ATA Command List

Description	Op Code	Description	Op Code
Check power mode	E5h	Security Disable Password	F6h
Data Set management	06h	Security Erase Prepare	F3h
DCO	B1H	Security Erase Unit	F4h
Download Microcode PIO	92h	Security Freeze Lock	F5h
Download Microcode DMA	93h	Security Set Password	F1h
Execute drive diagnostic	90h	Security Unlock	F2h
Flush cache	E7h	Seek	70h
Flush cache Ext	EAh	Set features	EFh
Identify device	ECh	Set Max Address	F9h
Idle	E3h	Set Max Address Ext	37h
Idle immediate	E1h	Set multiple mode	C6h
Initialize drive parameters	91h	Sleep	E6h
Read buffer	E4h	Smart	B0h
Read DMA (w/o retry)	C9h	Standby	E2h
Read DMA (w/retry)	C8h	Standby immediate	E0h
Read DMA Ext	25h	Write buffer	E8h
Read FPDMA QUEUED	60h	Write DMA (w/o retry)	CBh
Read Log Ext	2Fh	Write DMA (w/retry)	CAh
Read multiple	C4h	Write DMA Ext	35h
Read multiple Ext	29h	Write DMA FUA Ext	3Dh
Read native max address	F8h	Write FPDMA QUEUED	61h
Read native max Ext	27h	Write Log Ext	3Fh
Read sector(s) (w/o retry)	21h	Write multiple	C5h
Read sector(s) (w/retry)	20h	Write multiple Ext	39h
Read sector(s) Ext	24h	Write multiple FUA Ext	CEh
Read Verify Ext	42h	Write sector(s) (w/o retry)	31h
Read verify sector(s) (w/o retry)	41h	Write sector(s) (w/retry)	30h
Read verify sector(s) (w/retry)	40h	Write sector(s) Ext	34h
Recalibrate	10h	Write uncorrectable	45h

4.2 Identify Device Data

The following table detail the sector data returned by the IDENTIFY DEVICE command.

Word	F: Fixed V: Variable X: Both	Default Value	Description
0	F	045Ah	General configuration bit-significant information
1	X	3FFFh	Obsolete – Number of logical cylinders (16383)
2	V	0000h	Specific configuration
3	X	0010h	Obsolete – Number of logical heads (16)
4-5	X	02007E00h	Retired
6	X	003Fh	Obsolete – Number of logical sectors per logical track (63)
7-8	V	0h	Reserved for assignment by the Compact Flash Association
9	X	0h	Retired
10-19	F	Varies	Serial number (20 ASCII characters)
20-21	X	0h	Retired
22	X	0h	Obsolete
23-26	F	Varies	Firmware revision (8 ASCII characters)
27-46	F	Varies	Model number (xxxxxxxx)
47	F	8001h	7:0- Maximum number of sectors transferred per interrupt on MULTIPLE commands
48	F	0h	Reserved
49	F	0F00h	Capabilities
50	F	4000h	Capabilities
51-52	X	00000200h	Obsolete
53	F	0007h	Words 88 and 70:64 valid
54	X	3FFFh	Obsolete – Number of logical cylinders (16383)
55	X	0010h	Obsolete – Number of logical heads (16)
56	X	003Fh	Obsolete – Number of logical sectors per track (63)
57-58	X	00FBFC10h	Obsolete
59	F	0100h	Number of sectors transferred per interrupt on MULTIPLE commands
60-61	F	037DFF40h (32G) xxxxxxxxh (64G)	Total number of user addressable sectors

62	X	0h	Obsolete
63	F	0007h	Multi-word DMA modes supported/selected
64	F	0003h	PIO modes supported
65	F	0078h	Minimum Multiword DMA transfer cycle time per word
66	F	0078h	Manufacturer's recommended Multiword DMA transfer cycle time
67	F	0078h	Minimum PIO transfer cycle time without flow control
68	F	0078h	Minimum PIO transfer cycle time with IORDY flow control
69	F	0100h	Additional Supported (support download microcode DMA)
70	F	0000h	Reserved
71-74	F	0h	Reserved for the IDENTIFY PACKET DEVICE command
75	F	0h	Queue depth
76	F	0002h	Serial SATA capabilities
77	F	0h	Reserved for future Serial ATA definition
78	F	0000h	Serial ATA features supported
79	V	0000H	Serial ATA features enabled
80	F	00F8h	Major Version Number
81	F	0021h	Minor Version Number
82	F	7429h	Command set supported
83	F	7008h	Command set supported
84	F	4000h	Command set/feature supported extension
85	V	7028h	Command set/feature enabled
86	V	3000h	Command set/feature enabled
87	V	4000h	Command set/feature default
88	V	007Fh	Ultra DMA Modes
89	F	0000h	Time required for security erase unit completion
90	F	0000h	Time required for Enhanced security erase completion
91	V	0h	Current advanced power management value
92	V	0000h	Master Password Revision Code
93	F	0h	Hardware reset result. The contents of the bits (12:0) of this word shall change only during the execution of a hardware reset.
94	V	0h	Vendor's recommended and actual acoustic management value
95	F	0h	Stream Minimum Request Size
96	V	0h	Streaming Transfer Time – DMA
97	V	0h	Streaming Access Latency – DMA and PIO

98-99	F	0h	Streaming Performance Granularity
100-103	V	XXXXXXXXh (32G) XXXXXXXXh (64G) XXXXXXXXh (128G) XXXXXXXXh (256G)	Maximum user LBA for 48 bit Address feature set
104	V	0h	Streaming Transfer Time – PIO
105	F	0h	Reserved
106	F	0h	Physical sector size / Logical sector size
107	F	0h	Inter-seek delay for ISO-7779 acoustic testing in microseconds
108-111	F	0h	Unique ID
112-115	F	0h	Reserved
116	V	0h	Reserved
117-118	F	0h	Words per logical Sector
119	F	0h	Supported settings
120	F	0h	Command set/Feature Enabled/Supported
121-126	F	0h	Reserved
127	F	0h	Removable Media Status Notification feature set support
128	V	0h	Security status
129-159	X	0h	Vendor specific
160	F	0h	Compact Flash Association (CFA) power mode 1
161-175	X	0h	Reserved for assignment by the CFA
176-205	V	0h	Current media serial number
206-216	F	0h	Reserved
217	F	0h	Non-rotating media device
218-221	F	0h	Reserved
222	F	0h	Reserved
223-233	F	0h	Reserved
234		0h	Reserved
235		0h	Reserved
236-254	F	0h	Reserved
255	X	Varies	Integrity word (Checksum and Signature)

5. Physical Dimension

Dimension: 54mm(L) x 39mm(W) x 4.45mm(H)

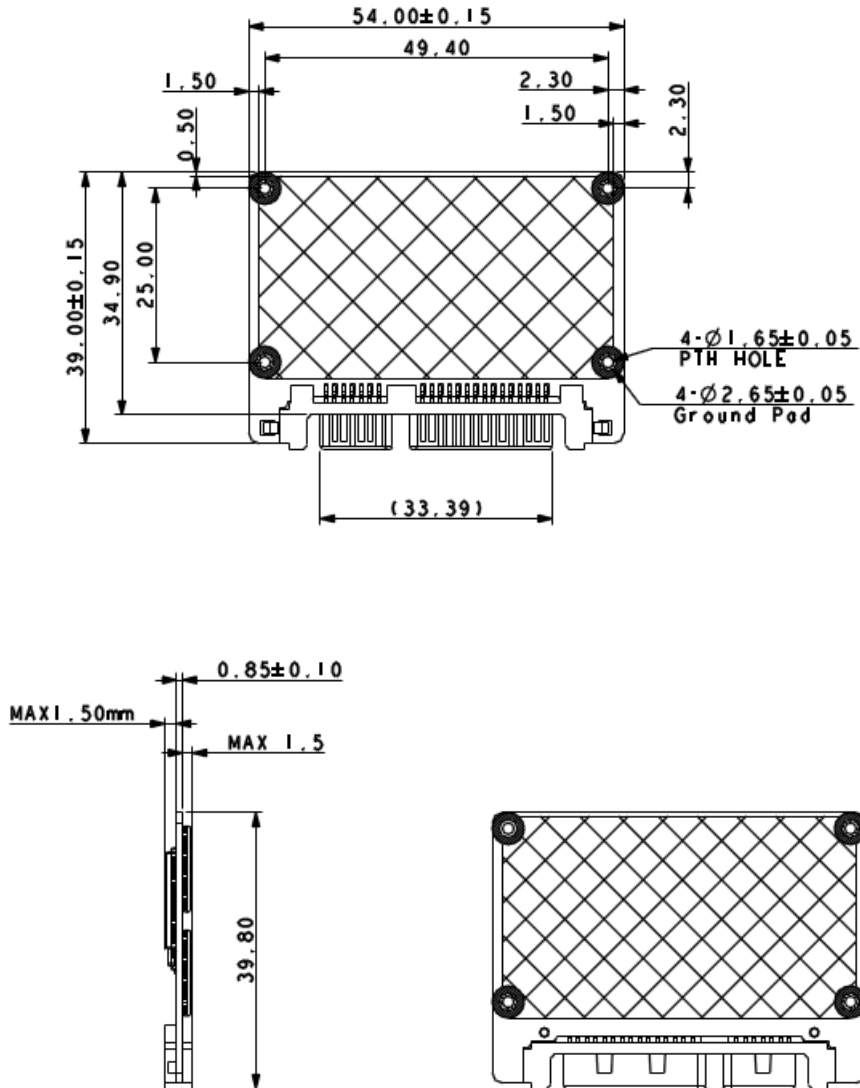

6. Part Numbers

Part Number	Description
USSSD004GBP-ISS	4GB SlimSATA SLC "I" Temp SSD
USSSD008GBP-ISS	8GB SlimSATA SLC "I" Temp SSD
USSSD016GBP-ISS	16GB SlimSATA SLC "I" Temp SSD
USSSD032GBP-ISS	32GB SlimSATA SLC "I" Temp SSD

Part Number	Description
USSSD004GBP-CSS	4GB SlimSATA SLC "C" Temp SSD
USSSD008GBP-CSS	8GB SlimSATA SLC "C" Temp SSD
USSSD016GBP-CSS	16GB SlimSATA SLC "C" Temp SSD
USSSD032GBP-CSS	32GB SlimSATA SLC "C" Temp SSD

Part Number	Description
USSSD016GBP-IMS	16GB SlimSATA MLC "I" Temp SSD
USSSD032GBP-IMS	32GB SlimSATA MLC "I" Temp SSD
USSSD064GBP-IMS	64GB SlimSATA MLC "I" Temp SSD
USSSD128GBP-IMS	128GB SlimSATA MLC "I" Temp SSD

Part Number	Description
USSSD016GBP-CMS	16GB SlimSATA MLC "C" Temp SSD
USSSD032GBP-CMS	32GB SlimSATA MLC "C" Temp SSD
USSSD064GBP-CMS	64GB SlimSATA MLC "C" Temp SSD
USSSD128GBP-CMS	128GB SlimSATA MLC "C" Temp SSD